

# NOA1213

## Ambient Light Sensor with Dark Current Compensation

### Description

The NOA1213 is a very low power ambient light sensor (ALS) with an analog current output and a power down mode to conserve power. Designed primarily for handheld device applications, the active power dissipation of this chip is less than 8  $\mu\text{A}$  at dark and its quiescent current consumption is less than 200 pA in power down mode. The device can operate over a very wide range of voltages from 2 V to 5.5 V. The NOA1213 employs proprietary CMOS image sensing technology from ON Semiconductor, including built-in dynamic dark current compensation to provide large signal to noise ratio (SNR) and wide dynamic range (DR) over the entire operating temperature range. The photopic optical filter provides a light response similar to that of the human eye. Together the photopic light response and dark current compensation insures accurate light level detection.

### Features

- Senses Ambient Light and Provides an Output Current Proportional to the Ambient Light Intensity
- Photopic Spectral Response
- Dynamic Dark Current Compensation
- Three Selectable Output Current Gain Modes in Approximately 10x Steps
- Power Down Mode
- Less than 14  $\mu\text{A}$  at 100 lux Active Power Consumption in Medium Gain Mode (Less than 8  $\mu\text{A}$  at Dark)
- Less than 200 pA Quiescent Power Dissipation in Power Down Mode at All Light Levels
- Linear Response Over the Full Operating Range
- Senses Intensity of Ambient Light from ~0 lux to Over 100,000 lux
- Wide Operating Voltage Range (2 V to 5.5 V)
- Wide Operating Temperature Range ( $-40^{\circ}\text{C}$  to  $85^{\circ}\text{C}$ )
- Drop-in Replacement Device in 1.6 x 1.6 mm Package
- These Devices are Pb-Free, Halogen Free/BFR Free and are RoHS Compliant

### Applications

- Saves display power in applications such as:
  - ◆ Cell Phones, PDAs, MP3 players, GPS
  - ◆ Cameras, Video Recorders
  - ◆ Mobile Devices with Displays or Backlit Keypads
  - ◆ Laptops, Notebooks, Digital Signage
  - ◆ LCD TVs and Monitors, Digital Picture Frames
  - ◆ Automobile Dashboard Displays and Infotainment
  - ◆ LED Indoor/Outdoor Residential and Street Lights



ON Semiconductor®

[www.onsemi.com](http://www.onsemi.com)



CUDFN6  
CU SUFFIX  
CASE 505AL

### PIN ASSIGNMENT

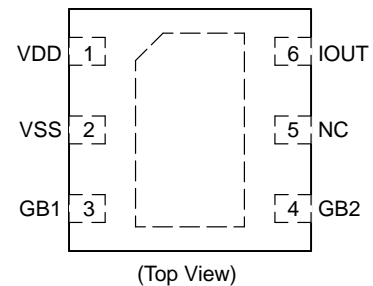

### ORDERING INFORMATION

Device	Package	Shipping†
NOA1213CUTAG*	CUDFN6 (Pb-Free)	2500 / Tape & Reel

†For information on tape and reel specifications, including part orientation and tape sizes, please refer to our Tape and Reel Packaging Specifications Brochure, BRD8011/D.

\*Temperature Range:  $-40^{\circ}\text{C}$  to  $85^{\circ}\text{C}$ .

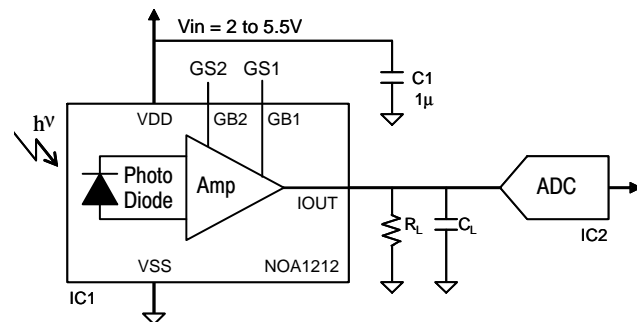

Figure 1. Typical Application Circuit

# NOA1213

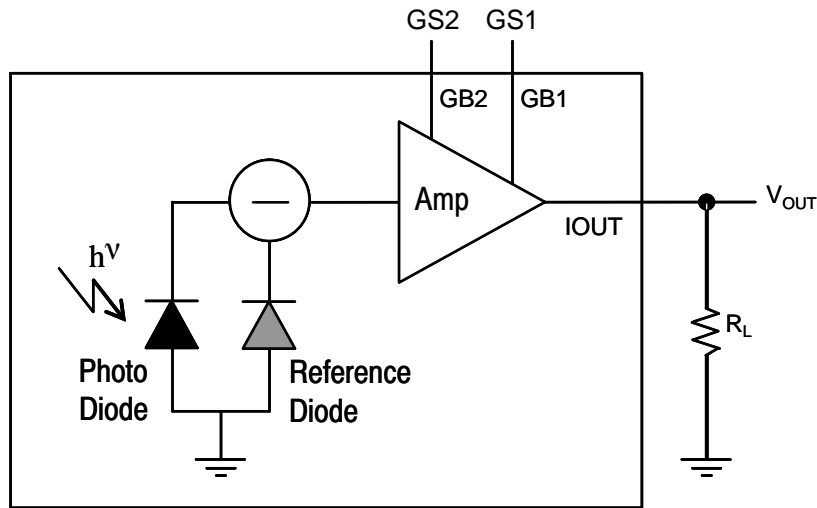

Figure 2. Simplified Block Diagram

Table 1. PIN FUNCTION DESCRIPTION

Pin	Pin Name	Description
1	VDD	Power pin.
2	VSS	Ground pin.
3	GB1	In conjunction with GB2, selects between three gain modes and power down.
4	GB2	In conjunction with GB1, selects between three gain modes and power down.
5	NC	Not connected. This may be connected to ground or left floating.
6	IOOUT	Analog current output.
EP	VSS	Exposed pad, internally connected to ground. Should be connected to ground.

Table 2. ABSOLUTE MAXIMUM RATINGS

Rating	Symbol	Value	Unit
Input power supply	$V_{DD}$	6	V
Input voltage range	$V_{IN}$	-0.3 to $V_{DD} + 0.3$	V
Output voltage range	$V_{OUT}$	-0.3 to $V_{DD} + 0.2$	V
Output current range	$I_o$	0 to 15	mA
Maximum Junction Temperature	$T_{J(max)}$	-40 to 85	°C
Storage Temperature	$T_{STG}$	-40 to 85	°C
ESD Capability, Human Body Model (Note 1)	$ESD_{HBM}$	2	kV
ESD Capability, Charged Device Model (Note 1)	$ESD_{CDM}$	750	V
ESD Capability, Machine Model (Note 1)	$ESD_{MM}$	150	V
Moisture Sensitivity Level	MSL	3	-
Lead Temperature Soldering (Note 2)	$T_{SLD}$	260	°C

Stresses exceeding those listed in the Maximum Ratings table may damage the device. If any of these limits are exceeded, device functionality should not be assumed, damage may occur and reliability may be affected.

1. This device incorporates ESD protection and is tested by the following methods:

ESD Human Body Model tested per EIA/JESD22-A114

ESD Charged Device Model tested per ESD-STM5.3.1-1999

ESD Machine Model tested per EIA/JESD22-A115

Latchup Current Maximum Rating:  $\leq 100$  mA per JEDEC standard: JESD78

2. For information, please refer to our Soldering and Mounting Techniques Reference Manual, SOLDERRM/D

# NOA1213

**Table 3. ELECTRICAL CHARACTERISTICS**

(Unless otherwise specified, these specifications apply over  $V_{DD} = 5.5\text{ V}$ ,  $-40^{\circ}\text{C} < T_A < 85^{\circ}\text{C}$ )

Rating	Test Conditions	Symbol	Min	Typ	Max	Unit
Power supply voltage		$V_{DD}$	2	3.0	5.5	V
Power supply current	$V_{DD} = 3.0\text{ V}$ , $E_v = 0\text{ lux}$ , H-Gain	$I_{DD\_0}$	6	8	12	$\mu\text{A}$
Power supply current	$V_{DD} = 3.0\text{ V}$ , $E_v = 100\text{ lux}$ , H-Gain	$I_{DD\_100}$	35	45	55	$\mu\text{A}$
Power down current	All light levels	$I_{DD\_PD}$		0.2	5	nA
Output current, high-gain	$E_v = 100\text{ lux}$ , White LED	$I_{o\_high}$	23.8	34	44.3	$\mu\text{A}$
Dark output current, high-gain	$V_{DD} = 3.0\text{ V}$ , $E_v = 0\text{ lux}$	$I_{o\_dark}$		10		nA
Wavelength of maximum response		$\lambda_m$		590		nm
White LED/fluorescent current ratio	$E_v = 100\text{ lux}$	$r_{LE}$		1.0		
Incandescent/fluorescent current ratio	$E_v = 100\text{ lux}$	$r_{IF}$		0.83		
Maximum output voltage	$E_v = 100\text{ lux}$ , $R_L = 220\text{ k}\Omega$ , H-Gain	$V_{OMAX}$	$V_{DD}-0.4$	$V_{DD}-0.1$	$V_{DD}$	V
Power down time	$E_v = 100\text{ lux}$ , H-Gain to PD	$t_{PD}$	1.5			ms
Wake up time	$E_v = 100\text{ lux}$ , PD to H-Gain	$t_{wu}$			300	$\mu\text{s}$
Low level input voltage		$V_{IL}$	-0.2		$0.25 V_{DD}$	V
High level input voltage		$V_{IH}$	$0.75 V_{DD}$		$V_{DD}+0.2$	V
Operating free-air temperature range		$T_A$	-40		85	$^{\circ}\text{C}$

Product parametric performance is indicated in the Electrical Characteristics for the listed test conditions, unless otherwise noted. Product performance may not be indicated by the Electrical Characteristics if operated under different conditions.

TYPICAL CHARACTERISTICS

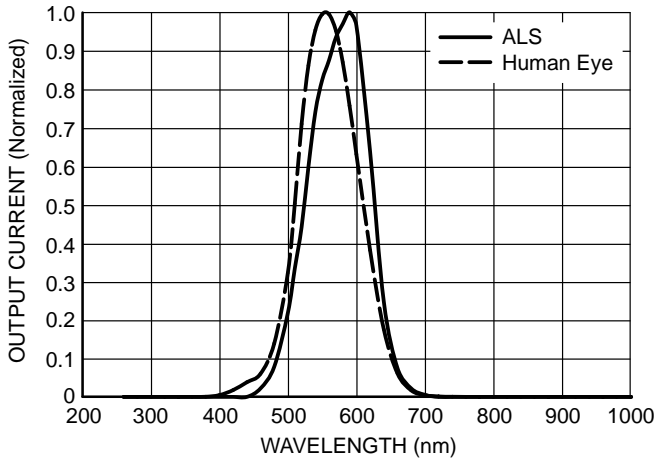

Figure 3. Spectral Response (Normalized)

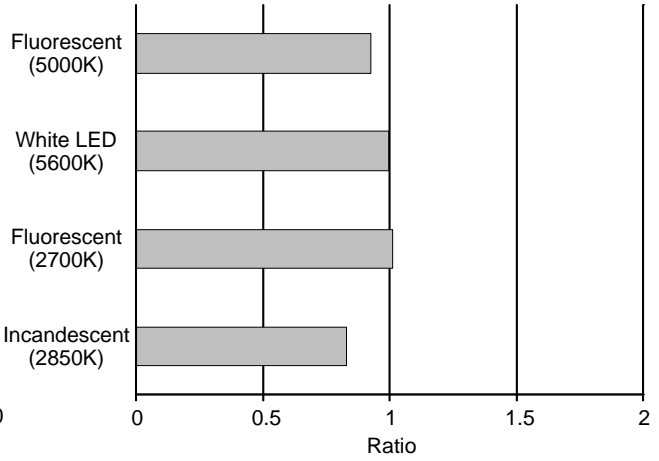

Figure 4. Light Source Dependency (Normalized to Fluorescent Light)

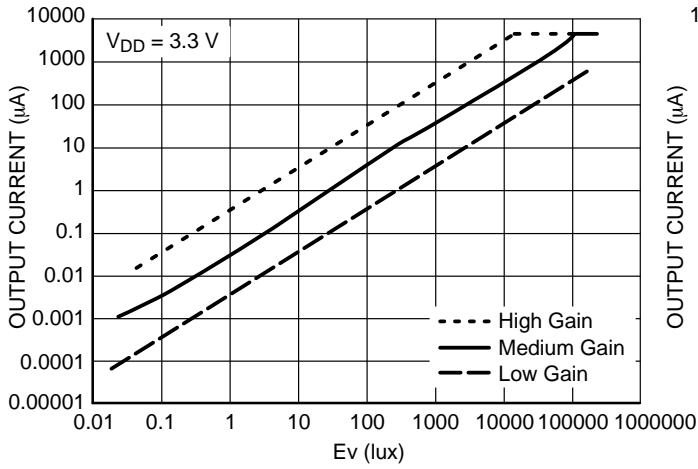

Figure 5. Output Current vs.  $E_v$

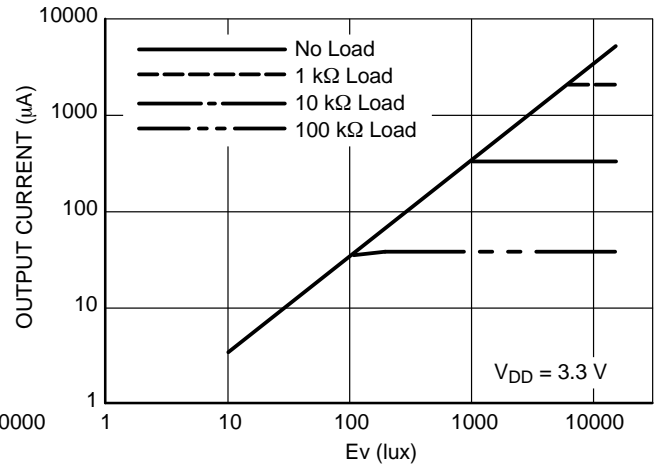

Figure 6. Output Current vs.  $E_v$  (High Gain Mode)

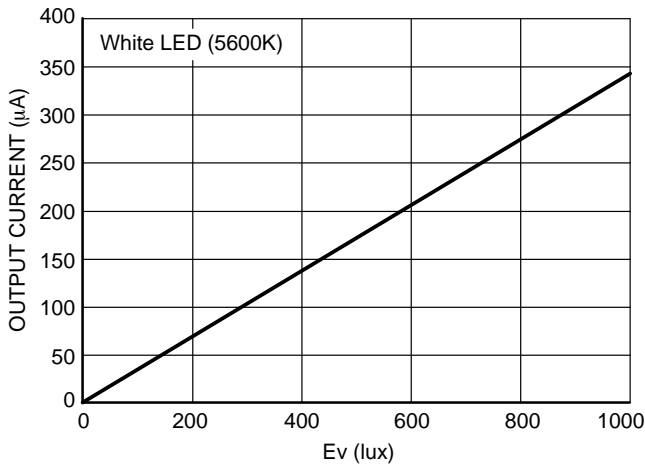

Figure 7. Output Current vs.  $E_v$ , 0–1000 lux (High Gain Mode)

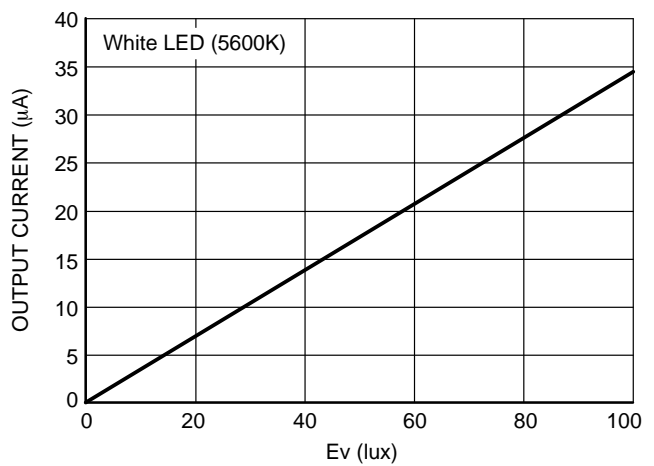

Figure 8. Output Current vs.  $E_v$ , 0–100 lux (High Gain Mode)

TYPICAL CHARACTERISTICS

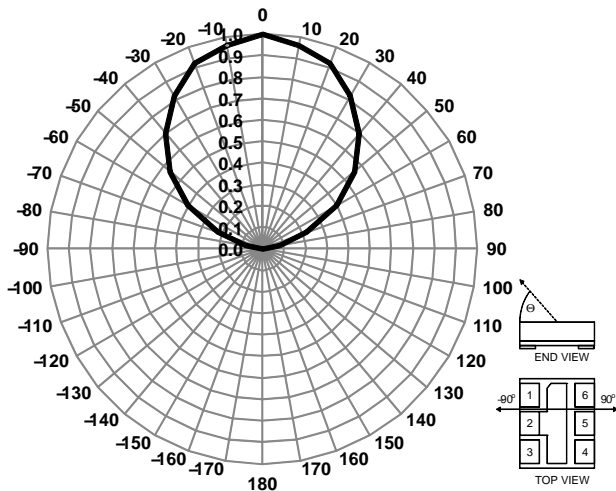

Figure 9. Output Current vs. Angle (End View, Normalized)

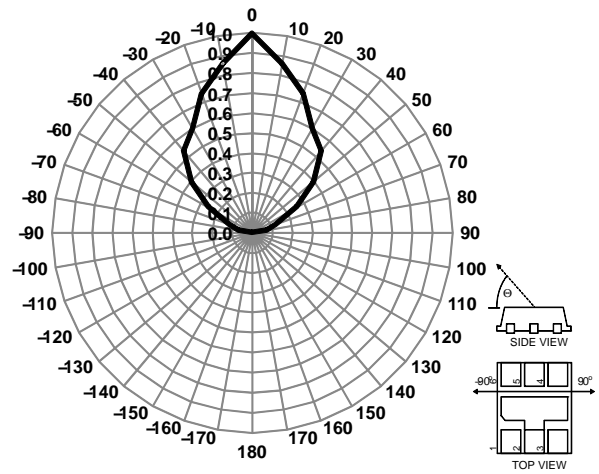

Figure 10. Output Current vs. Angle (Side View, Normalized)

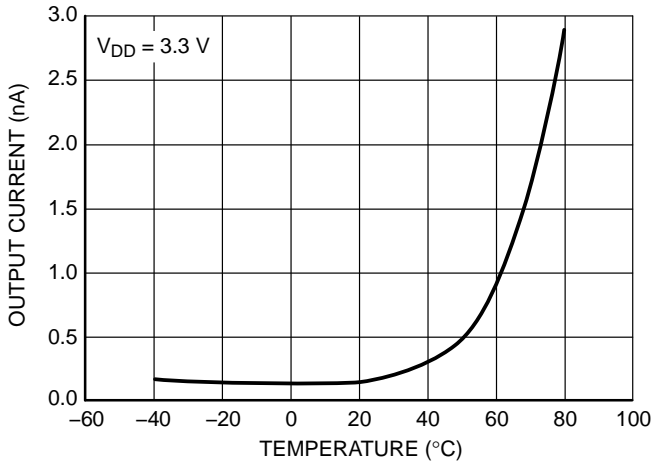

Figure 11. Output Current at 0 lux vs. Temperature (High Gain Mode)

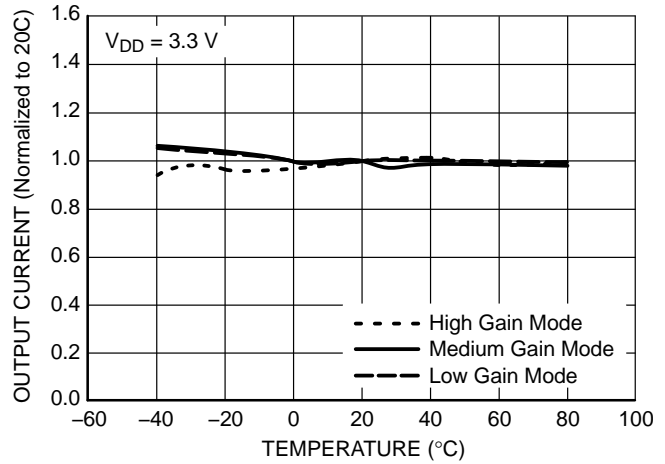

Figure 12. Output Current at 100 lux vs. Temperature

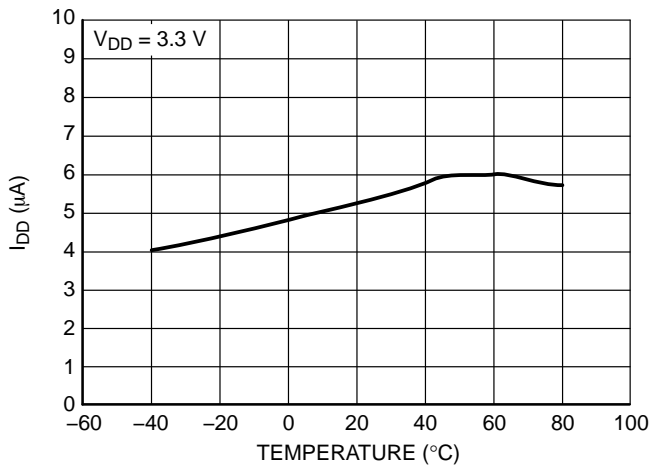

Figure 13. Supply Current at 0 lux vs. Temperature (High Gain Mode)

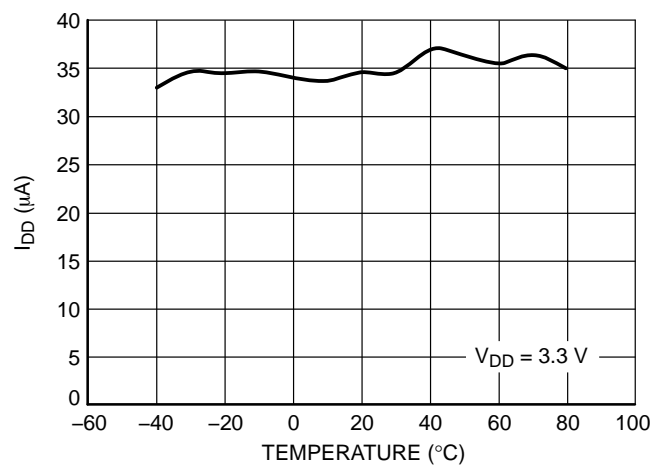

Figure 14. Supply Current at 100 lux vs. Temperature (High Gain Mode)

TYPICAL CHARACTERISTICS

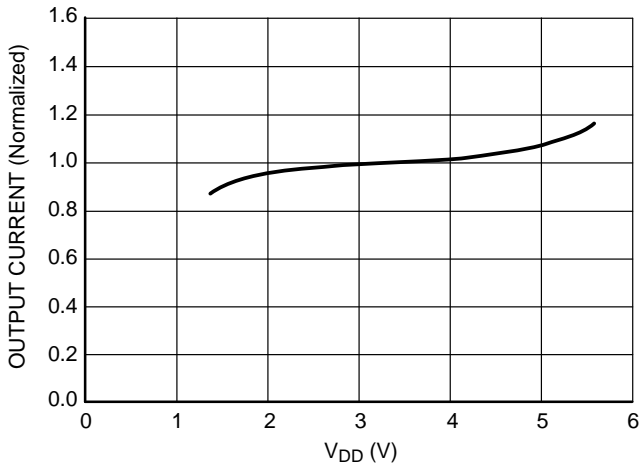

Figure 15. Output Current at 100 lux vs. Supply Voltage (High Gain Mode)

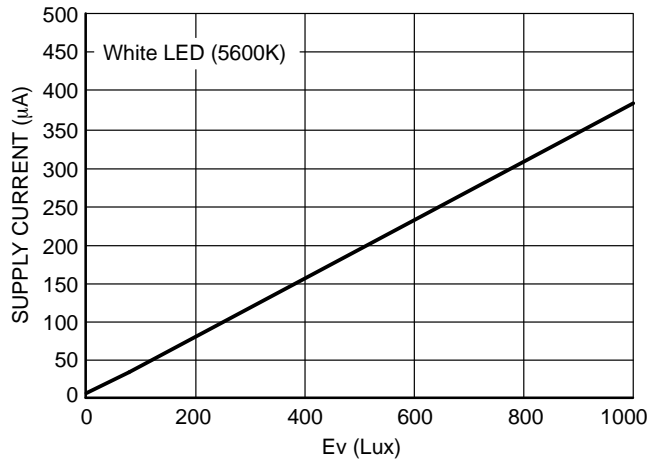

Figure 16. Supply Current vs. Ev (High Gain Mode)

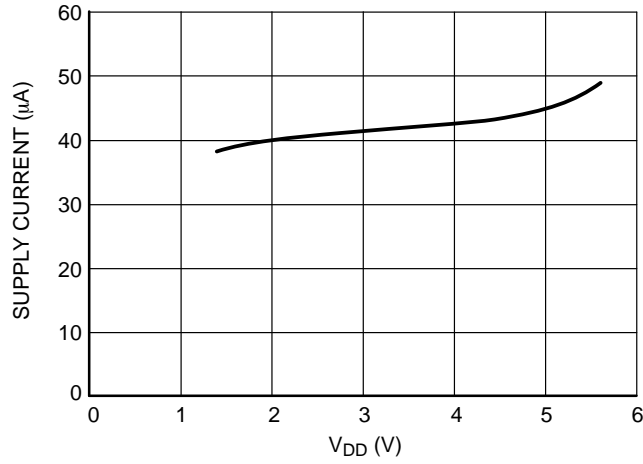

Figure 17. Supply Current vs. Supply Voltage (High Gain Mode)

## DESCRIPTION OF OPERATION

**Ambient Light Sensor Architecture**

The NOA1213 employs a sensitive photo diode fabricated in ON Semiconductor's standard CMOS process technology. The major components of this sensor are as shown in Figure 2. The photons which are to be detected pass through an ON Semiconductor proprietary color filter limiting extraneous photons and thus performing as a band pass filter on the incident wave front. The filter only

transmits photons in the visible spectrum which are primarily detected by the human eye and exhibits excellent IR rejection. The photo response of this sensor is as shown in Figure 3.

The ambient light signal detected by the photo diode is converted to an analog output current by an amplifier with programmable gain. Table 4 shows the gain setting and the corresponding light sensitivity.

**Table 4. PROGRAMMABLE GAIN SETTINGS**

GB2	GB1	Mode	Approximate Output Current @ 100 lux	Approximate Output Current @ 1000 lux	Saturation
0	0	Power Down	–	–	–
0	1	High Gain	34.1 $\mu$ A	365 $\mu$ A	~10,000 lux
1	0	Medium Gain	3.56 $\mu$ A	37.3 $\mu$ A	~100,000 lux
1	1	Low Gain	0.387 $\mu$ A	4.19 $\mu$ A	> 100,000 lux

**Power Down Mode**

This device can be placed in a power down mode by setting GB1 and GB2 to logic low level.

In order for proper operation of this mode GB1 and GB2 should stay low 1.5 ms.

**External Component Selection**

The NOA1213 outputs a current in direct response to the incident illumination. In many applications it is desirable to convert the output current into voltage. It may also be desirable to filter the effects of 50/60 Hz flicker or other light source transients.

Conversion from current to voltage may be accomplished by adding load resistor  $R_L$  to the output. The value of  $R_L$  is bounded on the high side by the potential output saturation of the amplifier at high ambient light levels.  $R_L$  is bounded on the low side by the output current limiting of the internal amplifier and to minimize power consumption.

Equation 1 describes the relationship of light input to current output for the High-Gain mode.

$$I_{OUT} = (34.5 \mu\text{A}/100 \text{ lux}) * E_V \quad (\text{eq. 1})$$

By adding  $R_L$  to the output,  $I_{OUT}$  is converted into a voltage according to Equation 2.

$$V_{OUT} = I_{OUT} * R_L = (34.5 \mu\text{A}/100 \text{ lux}) * E_V * R_L \quad (\text{eq. 2})$$

The range of the output voltage is limited by the output stage to the  $V_{OMAX}$  parameter value of  $V_{DD} - 0.4 \text{ V}$  at the

maximum desired  $E_V$  as shown in Equation 3. Equation 4 computes the value for  $R_L$  (High-Gain mode).

$$V_{OMAX} = (34.5 \mu\text{A}/100 \text{ lux}) * E_{VMAX} * R_L \quad (\text{eq. 3})$$

$$R_L = (V_{DD} - 0.4 \text{ V})/E_{VMAX} * (100 \text{ lux}/34.5 \mu\text{A}) \quad (\text{eq. 4})$$

For example, consider a 5 V supply with a desired  $E_{VMAX} = 1000 \text{ lux}$ , the value of  $R_L$  would be 13.3 k $\Omega$ . The value for  $R_L$  can easily be computed for different NOA1213 gain ranges by substituting the appropriate output current at 100 lux from Table 4.

The optional capacitor  $C_L$  can be used to form a low-pass filter to remove 50/60 Hz filter or other unwanted noise sources as computed with Equation 5.

$$C_L = 1/2\pi f_c R_L \quad (\text{eq. 5})$$

For our example, to filter out 60Hz flicker the value of  $C_L$  would be 200 nF.

**Power Supply Bypassing and Printed Circuit Board Design**

Power supply bypass and decoupling can typically be handled with a low cost 0.1  $\mu$ F to 1.0  $\mu$ F capacitor.

The exposed pad on the bottom of the package is internally connected to VSS pin 2 and should be soldered to the printed circuit board.

NOTE: Oblique illumination with IR light can disrupt normal operation. Please request App Note "Known NOA1213CUTAG Performance Aberrations" for more details.

# MECHANICAL CASE OUTLINE

## PACKAGE DIMENSIONS

ON Semiconductor®



SCALE 2:1

CUDFN6 1.6x1.6, 0.5P  
CASE 505AL  
ISSUE A

DATE 09 FEB 2017

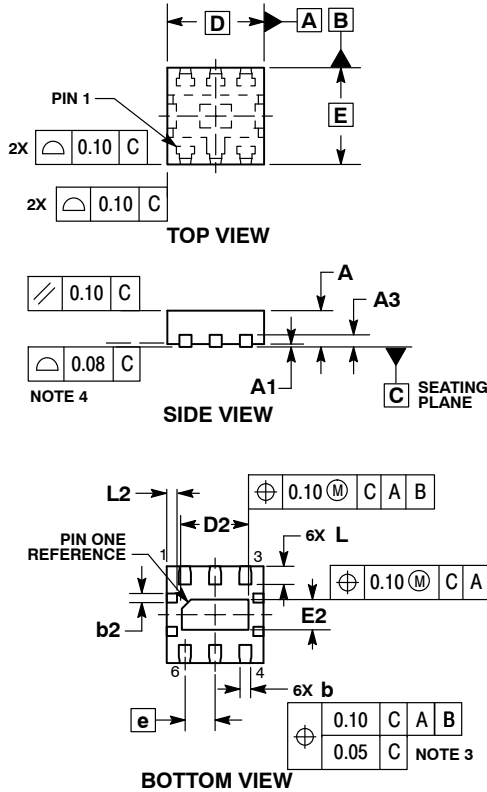

NOTES:

1. DIMENSIONING AND TOLERANCING PER ASME Y14.5M, 1994.
2. CONTROLLING DIMENSION: MILLIMETERS.
3. DIMENSION b APPLIES TO PLATED TERMINAL AND IS MEASURED BETWEEN 0.10 AND 0.20MM FROM THE TERMINAL TIP.
4. COPLANARITY APPLIES TO THE EXPOSED PAD AS WELL AS THE TERMINALS.

DIM	MILLIMETERS	
	MIN	MAX
A	0.55	0.65
A1	0.00	0.05
A3	0.20	REF
b	0.15	0.25
b2	0.15	REF
D	1.60	BSC
D2	1.05	1.15
E	1.60	BSC
E2	0.45	0.55
e	0.50	BSC
L	0.25	0.35
L2	0.17	REF

**GENERIC MARKING DIAGRAM\***

\*No marking due to clear package

**RECOMMENDED MOUNTING FOOTPRINT\***

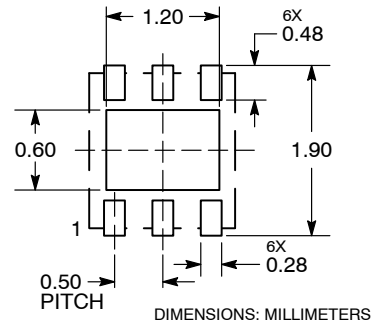

\*For additional information on our Pb-Free strategy and soldering details, please download the ON Semiconductor Soldering and Mounting Techniques Reference Manual, SOLDERRM/D.

<b>DOCUMENT NUMBER:</b>	<b>98AON89262F</b>	Electronic versions are uncontrolled except when accessed directly from the Document Repository. Printed versions are uncontrolled except when stamped "CONTROLLED COPY" in red.
<b>DESCRIPTION:</b>	<b>CUDFN6, 1.6X1.6, 0.5P</b>	<b>PAGE 1 OF 1</b>

ON Semiconductor and are trademarks of Semiconductor Components Industries, LLC dba ON Semiconductor or its subsidiaries in the United States and/or other countries. ON Semiconductor reserves the right to make changes without further notice to any products herein. ON Semiconductor makes no warranty, representation or guarantee regarding the suitability of its products for any particular purpose, nor does ON Semiconductor assume any liability arising out of the application or use of any product or circuit, and specifically disclaims any and all liability, including without limitation special, consequential or incidental damages. ON Semiconductor does not convey any license under its patent rights nor the rights of others.

**onsemi**, **Onsemi**, and other names, marks, and brands are registered and/or common law trademarks of Semiconductor Components Industries, LLC dba "**onsemi**" or its affiliates and/or subsidiaries in the United States and/or other countries. **onsemi** owns the rights to a number of patents, trademarks, copyrights, trade secrets, and other intellectual property. A listing of **onsemi**'s product/patent coverage may be accessed at [www.onsemi.com/site/pdf/Patent-Marking.pdf](http://www.onsemi.com/site/pdf/Patent-Marking.pdf). **onsemi** reserves the right to make changes at any time to any products or information herein, without notice. The information herein is provided "as-is" and **onsemi** makes no warranty, representation or guarantee regarding the accuracy of the information, product features, availability, functionality, or suitability of its products for any particular purpose, nor does **onsemi** assume any liability arising out of the application or use of any product or circuit, and specifically disclaims any and all liability, including without limitation special, consequential or incidental damages. Buyer is responsible for its products and applications using **onsemi** products, including compliance with all laws, regulations and safety requirements or standards, regardless of any support or applications information provided by **onsemi**. "Typical" parameters which may be provided in **onsemi** data sheets and/or specifications can and do vary in different applications and actual performance may vary over time. All operating parameters, including "Typicals" must be validated for each customer application by customer's technical experts. **onsemi** does not convey any license under any of its intellectual property rights nor the rights of others. **onsemi** products are not designed, intended, or authorized for use as a critical component in life support systems or any FDA Class 3 medical devices or medical devices with a same or similar classification in a foreign jurisdiction or any devices intended for implantation in the human body. Should Buyer purchase or use **onsemi** products for any such unintended or unauthorized application, Buyer shall indemnify and hold **onsemi** and its officers, employees, subsidiaries, affiliates, and distributors harmless against all claims, costs, damages, and expenses, and reasonable attorney fees arising out of, directly or indirectly, any claim of personal injury or death associated with such unintended or unauthorized use, even if such claim alleges that **onsemi** was negligent regarding the design or manufacture of the part. **onsemi** is an Equal Opportunity/Affirmative Action Employer. This literature is subject to all applicable copyright laws and is not for resale in any manner.

## PUBLICATION ORDERING INFORMATION

### LITERATURE FULFILLMENT:

Email Requests to: [orderlit@onsemi.com](mailto:orderlit@onsemi.com)

**onsemi Website:** [www.onsemi.com](http://www.onsemi.com)

### TECHNICAL SUPPORT

**North American Technical Support:**

Voice Mail: 1 800-282-9855 Toll Free USA/Canada

Phone: 011 421 33 790 2910

**Europe, Middle East and Africa Technical Support:**

Phone: 00421 33 790 2910

For additional information, please contact your local Sales Representative

# Mouser Electronics

Authorized Distributor

Click to View Pricing, Inventory, Delivery & Lifecycle Information:

[onsemi:](#)

[NOA1213CUTAG](#)